

**KLT-PAB18-AR0234 V1.0****2.3MP OnSemi AR0234 Global Shutter DVP Parallel Interface
M12 Auto Focus Camera Module**

Front View

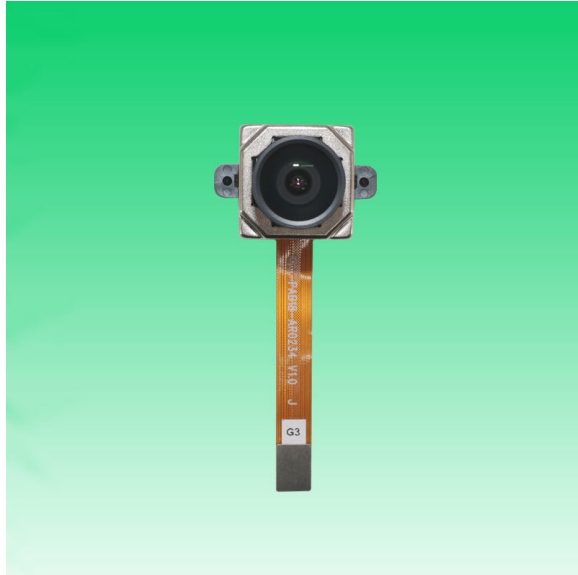

Back View

Specifications

| | |
|---------------------------------|---------------------------------------|
| Camera Module No. | KLT-PAB18-AR0234 V1.0 |
| Resolution | 2.3MP |
| Image Sensor | AR0234 Global Shutter |
| Sensor Type | 1/2.6" |
| Pixel Size | 3.0 um x 3.0 um |
| EFL | 2.70 mm |
| F.NO | 2.00 |
| Pixel | 1920 x 1200 |
| View Angle | 165.0°(DFOV) 133.0°(HFOV) 79.0°(VFOV) |
| Lens Dimensions | 18.00 x 18.00 x 22.82 mm |
| Module Size | 60.00 x 24.00 mm |
| Module Type | Auto Focus |
| Interface | MIPI |
| Auto Focus VCM Driver IC | DW9714P |
| Lens Type | 650nm IR Cut |
| Operating Temperature | -30°C to +70°C |
| Mating Connector | AXT524124 |



KLT-PAB18-AR0234 V1.0
2.3MP OnSemi AR0234 Global Shutter DVP Parallel Interface
M12 Auto Focus Camera Module



Top View



Side View

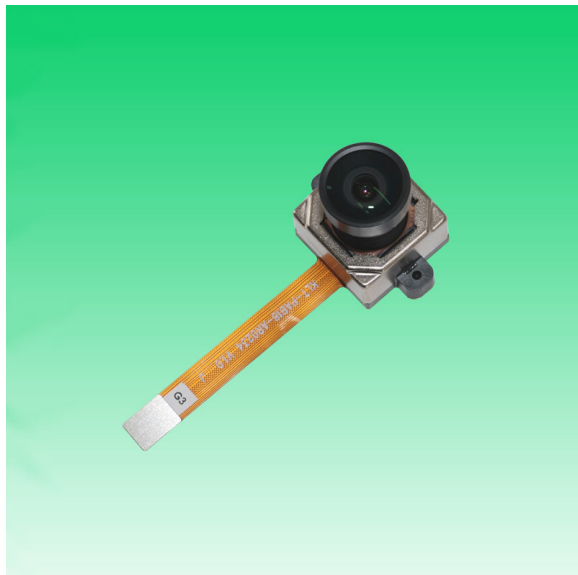

Bottom View



Mating Connector

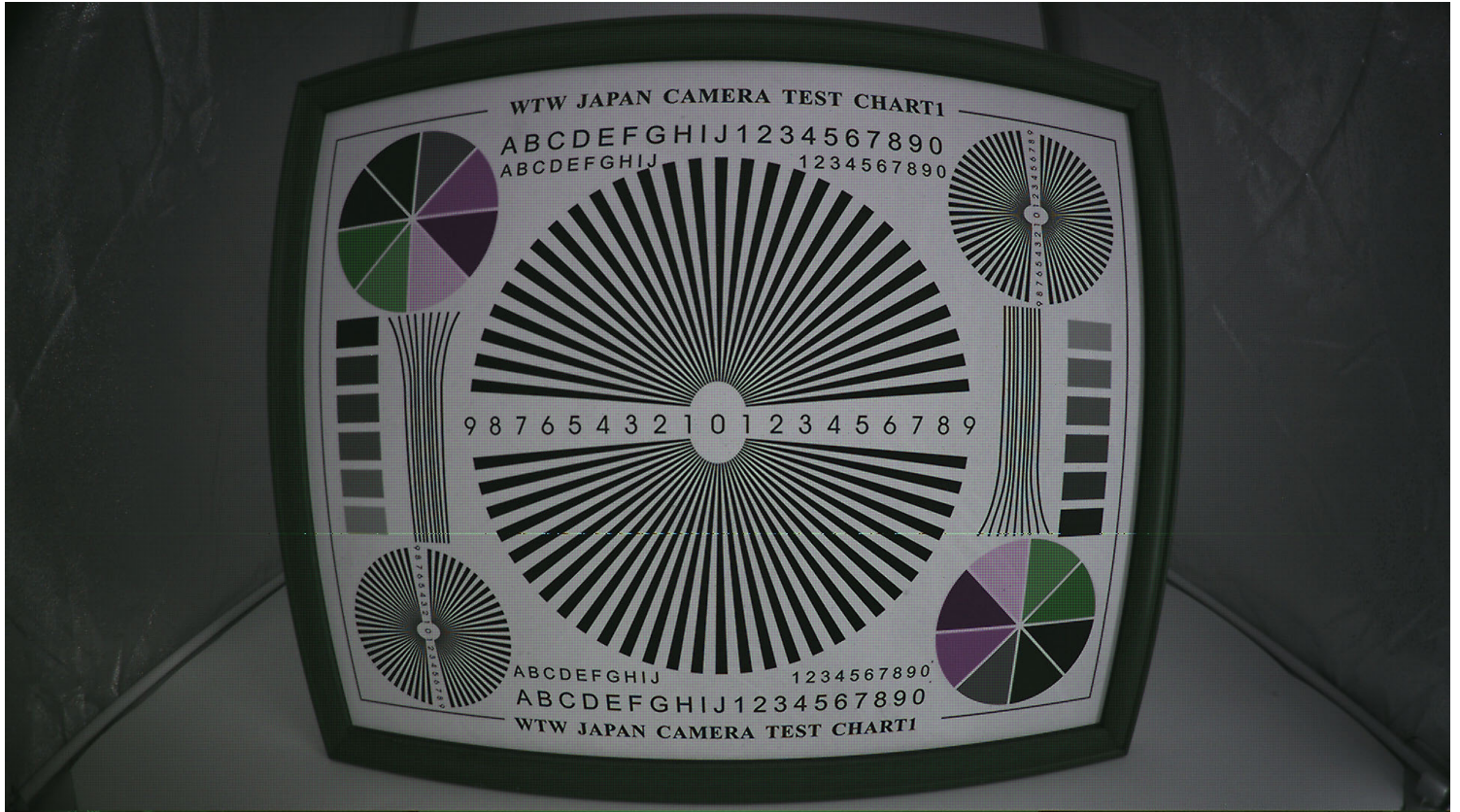

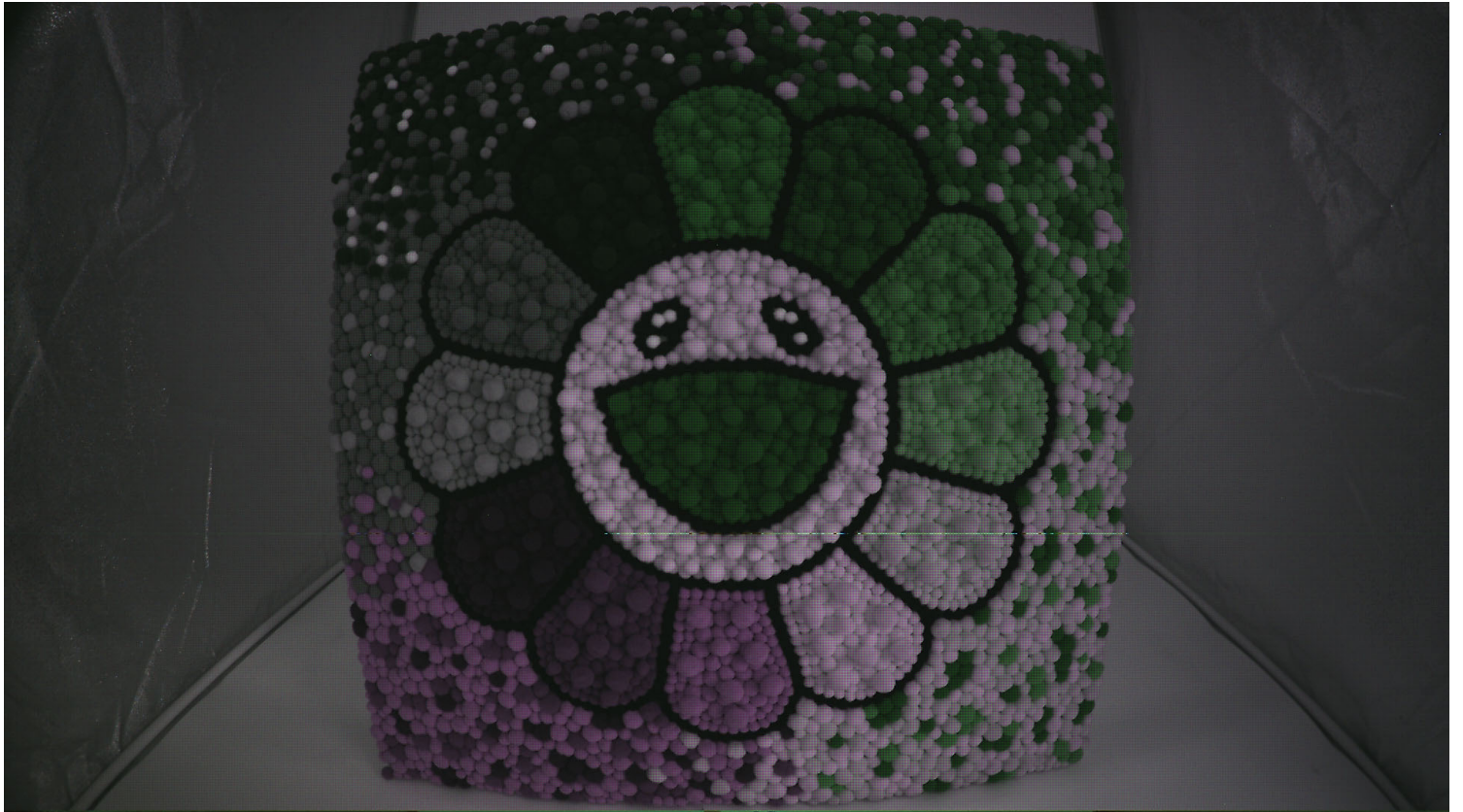
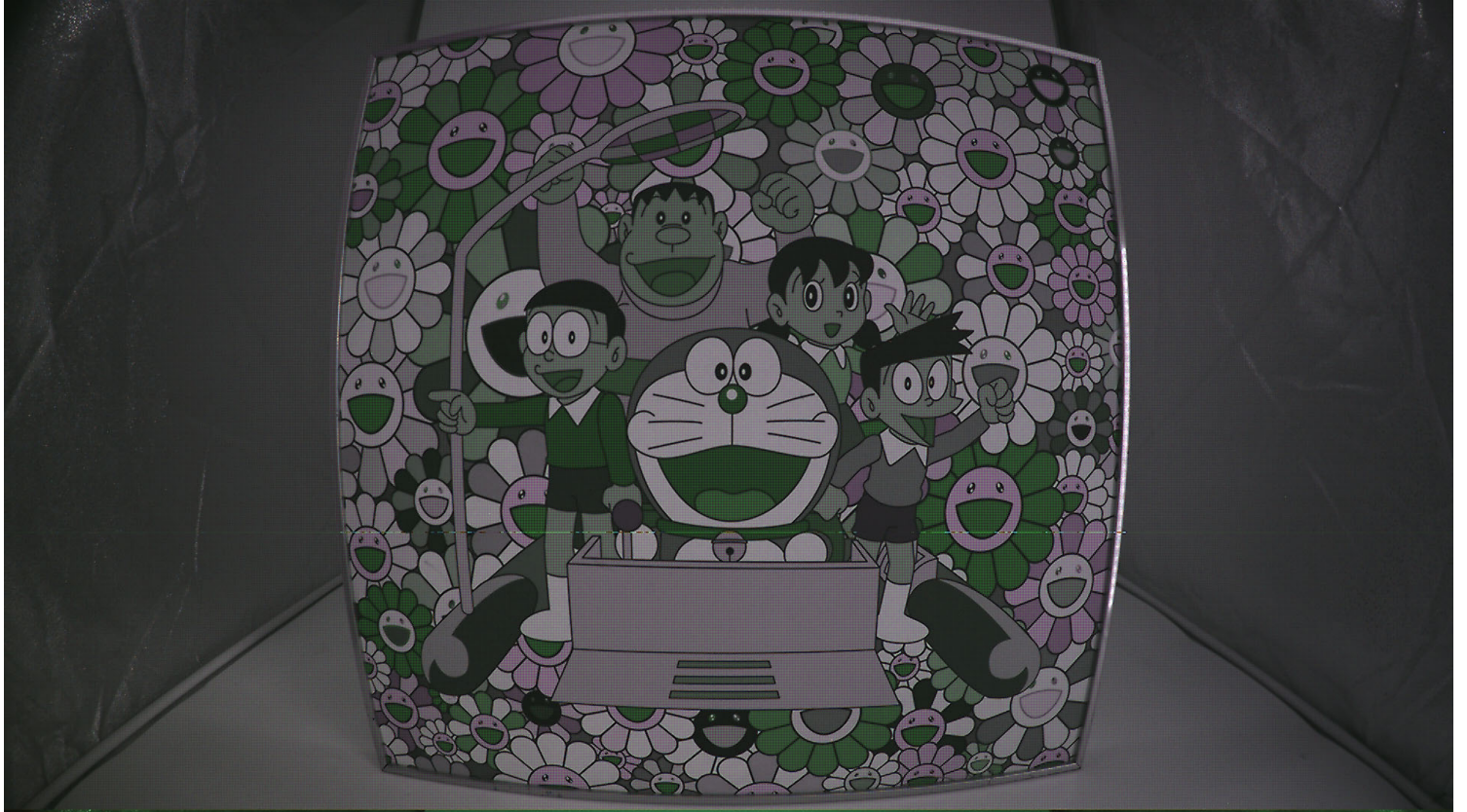
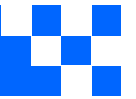

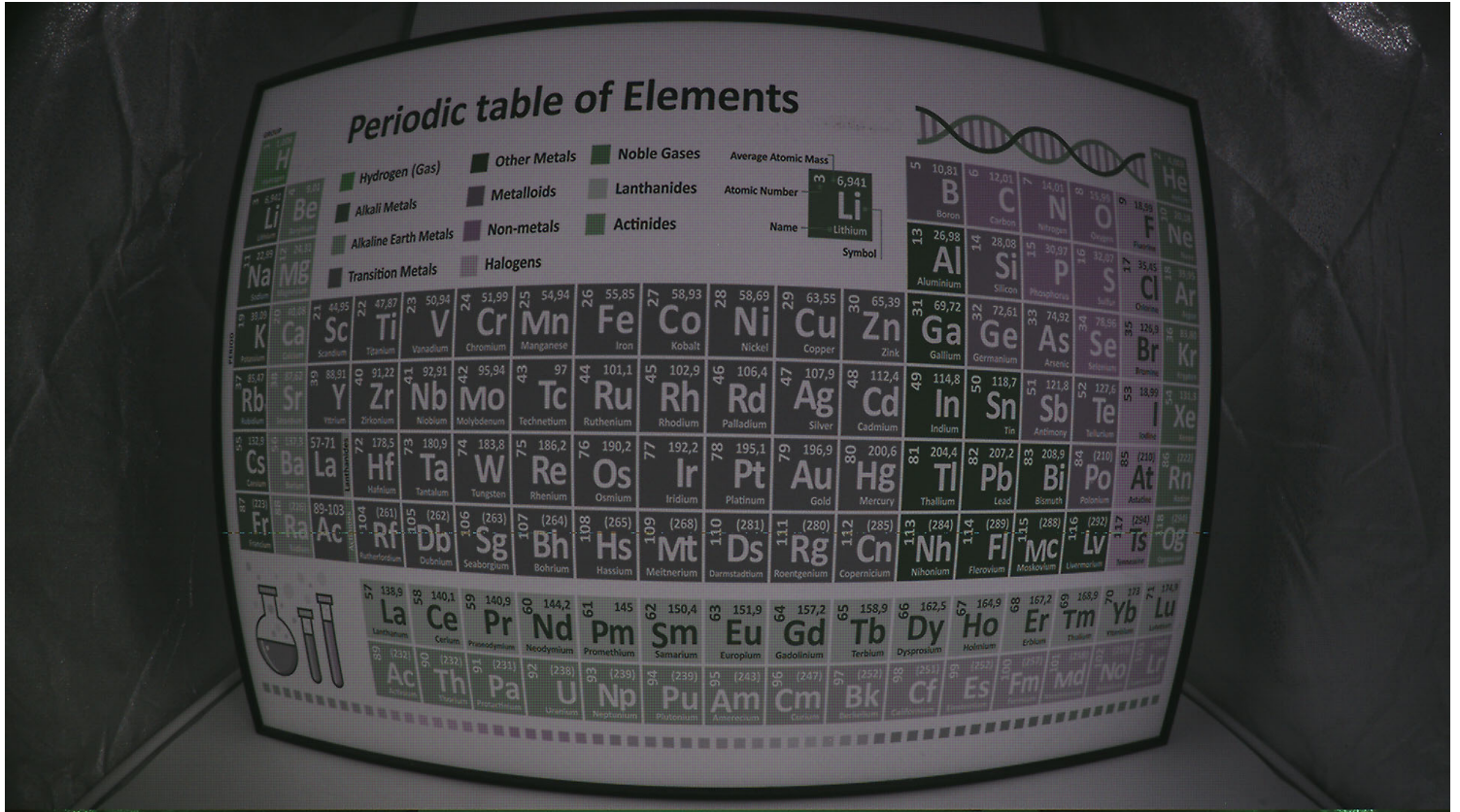

| RoHS | |
|------|-------------|
| PIN | SIGNAL |
| 1 | XSHUTDOWN |
| 2 | EXTCLK |
| 3 | RESET_BAR |
| 4 | SDATA |
| 5 | SCLK |
| 6 | AFVDD 2.8V |
| 7 | DOVDD 1.8V |
| 8 | DVDD 1.2V |
| 9 | AVDD 2.8V |
| 10 | AGND |
| 11 | LINE_VALID |
| 12 | FRAME_VALID |
| 13 | PIXCLK |
| 14 | D0 |
| 15 | D1 |
| 16 | D2 |
| 17 | D3 |
| 18 | D4 |
| 19 | D5 |
| 20 | D6 |
| 21 | D7 |
| 22 | D8 |
| 23 | D9 |
| 24 | DGND |

| Version | Information |
|---------|---------------|
| V1.0 | First Version |

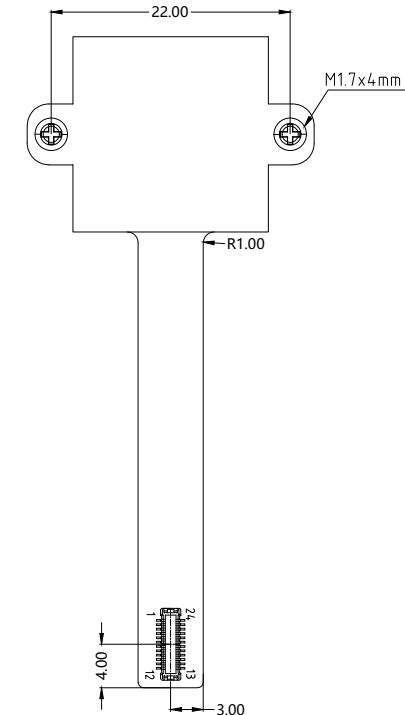
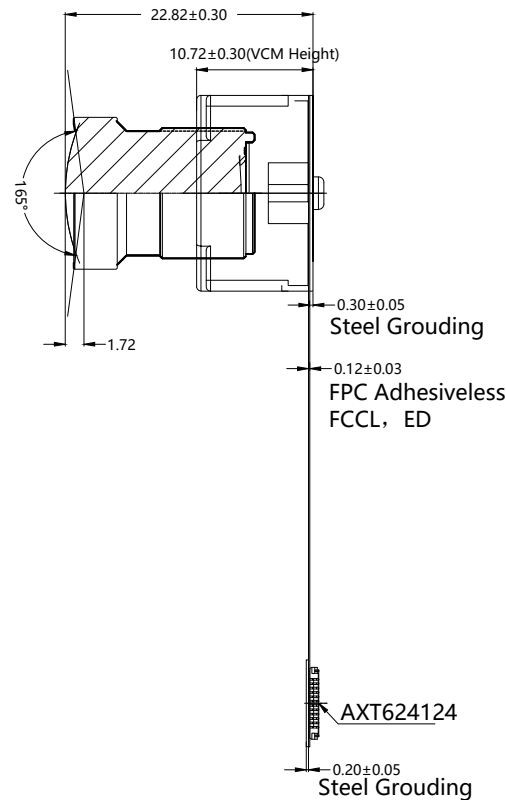
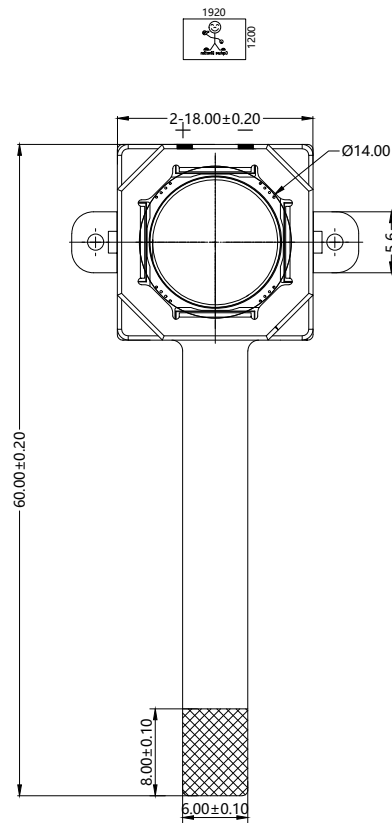

NOTE:
 1.The device slave address:0x30(write);0x31(r);
 2.Driver IC:DW9714P

TOP VIEW

SIDE VIEW

BOTTOM VIEW

Parameters:

1、 Sensor specification:

Image Sensor: AR0234CSSC00SUKA0-CP
 Pixel: 3.0um*3.0um
 Lens Type: 1/2.6
 Important Voltage Description:
 DVDD1.2V (external power supply);

2、 Lens specification:

FOV: 165°(D);133°(H);79°(V);
 F/NO.: 2.0
 TV distortion: <-18%
 Focal length: 2.7mm
 Composition: 6G+IR FILTER
 IR Cut Coating: 650nm±10nm@50%

Kai Lap Technologies Group Ltd

| | | | | | |
|-------------|-------|------------------|-----------------------|-----------------|--------------|
| Designed By | Kevin | Model Name: | KLT-PAB18-AR0234 V1.0 | | |
| Checked By | Jacky | Projection Type: | Unit: mm | Date: 12/2/2025 | |
| | | | Scale: 1:1 | Sheet: 1 of 1 | Version: 1/0 |

AR0234CS

1/2.6-inch 2.3 Mp CMOS Digital Image Sensor with Global Shutter

Product Overview

For complete documentation, see the data sheet.

The AR0234CS is a 1/2.6-inch 2Mp CMOS digital image sensor with an active-pixel array of 1920 (H) x 1200 (V). It incorporates a new innovative global shutter pixel design optimized for accurate and fast capture of moving scenes at 120 frame per second, full resolution. The sensor produces clear, low noise images in both low-light and bright scenes. It includes sophisticated camera functions such as auto exposure control, windowing, row skip mode, column-skip mode, pixel-binning, and both video and single frame modes. It is programmable through a simple two-wire serial interface. The AR0234CS produces extraordinarily clear, sharp digital pictures with an industry leading Global Shutter Efficiency, and its ability to capture both continuous video and single frames makes it the perfect choice for a wide range of applications, including scanning, autonomous mobility, surveillance and industrial quality control.

Features

- Best in Class Global Shutter Efficiency
- Low Dark Current/Hot Pixels
- High Linear Full Well
- Low Operational Power
- Small Form Factor
- Built-In Statistics Engine
- Multiple Functional Modes - Row & Col Skip Modes, Pixel Binning

Applications

- Gesture recognition
- 3D scanning
- Position tracking
- Machine vision
- AR/VR/MR/XR

































Benefits

- Superior Image Quality for fast-moving objects
- Reduced Total Noise Floor, Higher SNR delivering High Image Fidelity
- High Dynamic Range, delivers higher image clarity
- Suitable of Battery Powered Applications
- Ideal for Space Constrained Applications
- Offloads Image Processor Loads, provides scene details with Prog. ROI
- Application-specific Image Quality Selections with Performance/Power Trade-offs

End Products

- Autonomous Mobile Robots
- Autonomous Guide Vehicles (Drones)
- Video Doorbells
- AR/VR/MR Headsets
- Barcode Readers

Part Electrical Specifications

| Product | Pricing (\$/Unit) | Compliance | Status | Type | Megapixels | Frame Rate (fps) | Optical Format | Shutter Type | Pixel Size (µm) | Output Interface | Color | Package Type |
|-----------------------|-------------------|---|--------|------|------------|------------------|----------------|----------------|-----------------|------------------|-------|--------------|
| AR0234CSSC00SUD20 | |   | NEW | CMOS | 2.3 | 120 | 1/2.6 inch | Global Shutter | 3.0 x 3.0 | | Color | |
| AR0234CSSC00SUKA0-CP | |   | Active | CMOS | 2.3 | 120 | 1/2.6 inch | Global Shutter | 3.0 x 3.0 | | Color | ODCSP-83 |
| AR0234CSSC00SUKA0-CP1 | |   | Active | CMOS | 2.3 | 120 | 1/2.6 inch | Global Shutter | 3.0 x 3.0 | | Color | ODCSP-83 |
| AR0234CSSC00SUKA0-CR | |   | Active | CMOS | 2.3 | 120 | 1/2.6 inch | Global Shutter | 3.0 x 3.0 | | Color | ODCSP-83 |
| AR0234CSSC28SUD20 | |   | NEW | CMOS | 2.3 | 120 | 1/2.6 inch | Global Shutter | 3.0 x 3.0 | | Color | |
| AR0234CSSC28SUKA0-CP | |   | Active | CMOS | 2.3 | 120 | 1/2.6 inch | Global Shutter | 3.0 x 3.0 | | Color | ODCSP-83 |
| AR0234CSSC28SUKA0-CP1 | |   | Active | CMOS | 2.3 | 120 | 1/2.6 inch | Global Shutter | 3.0 x 3.0 | | Color | ODCSP-83 |
| AR0234CSSC28SUKA0-CR | |   | Active | CMOS | 2.3 | 120 | 1/2.6 inch | Global Shutter | 3.0 x 3.0 | | Color | ODCSP-83 |
| AR0234CSSM00SUD20 | |   | NEW | CMOS | 2.3 | 120 | 1/2.6 inch | Global Shutter | 3.0 x 3.0 | | Mono | |
| AR0234CSSM00SUKA0-CP | |   | Active | CMOS | 2.3 | 120 | 1/2.6 inch | Global Shutter | 3.0 x 3.0 | | Mono | ODCSP-83 |
| AR0234CSSM00SUKA0-CP1 | |   | Active | CMOS | 2.3 | 120 | 1/2.6 inch | Global Shutter | 3.0 x 3.0 | | Mono | ODCSP-83 |
| AR0234CSSM00SUKA0-CR | |   | Active | CMOS | 2.3 | 120 | 1/2.6 inch | Global Shutter | 3.0 x 3.0 | | Mono | ODCSP-83 |
| AR0234CSSM28SUD20 | |   | NEW | CMOS | 2.3 | 120 | 1/2.6 inch | Global Shutter | 3.0 x 3.0 | | Mono | |
| AR0234CSSM28SUKA0-CP | |   | Active | CMOS | 2.3 | 120 | 1/2.6 inch | Global Shutter | 3.0 x 3.0 | | Mono | ODCSP-83 |
| AR0234CSSM28SUKA0-CP1 | |   | Active | CMOS | 2.3 | 120 | 1/2.6 inch | Global Shutter | 3.0 x 3.0 | | Mono | ODCSP-83 |
| AR0234CSSM28SUKA0-CR | |   | Active | CMOS | 2.3 | 120 | 1/2.6 inch | Global Shutter | 3.0 x 3.0 | | Mono | ODCSP-83 |

FEATURES

- 120mA output driver with 10-bit resolution DAC
- Smart Actuator Control (SAC™) modes
- Supply voltage (V_{DD}): 2.3V to 4.3V
- I/O voltage (V_{IN}): 1.8V to V_{DD}
- Fast mode and Fast mode plus I²C interface compatible
- Power On Reset (POR)
- Power Down (PD) mode current consumption less than 1uA
- Package: 6-pin WLCSP (0.77mm x 1.14mm x 0.30mm)

APPLICATIONS

- Mobile camera
- Digital still camera
- Camcorder
- Web camera
- Action camera

GENERAL DESCRIPTION

The DW9714P designed for linear control of Voice Coil Motors (VCM). This device is compatible with DW9714. The DW9714P has a single 10-bit DAC with 120mA output current sink capability. This device features SAC™ mode which can minimize the mechanical vibration and achieve very fast mechanical settling time. The SAC™ is protected by patent and registered trademark of DONGWOON ANATECH.

The DW9714P operates from a single 2.3V to 4.3V supply. The internal DAC is controlled via an I²C serial interface that operates at clock rate up to 1MHz. The I²C address for the DW9714P is 0x18. The DW9714P offers PD mode with current consumption less than 1uA.

The DW9714P can be used for auto focus applications in mobile cameras, digital still cameras, camcorders, web cameras and action cameras.

TYPICAL APPLICATION CIRCUIT

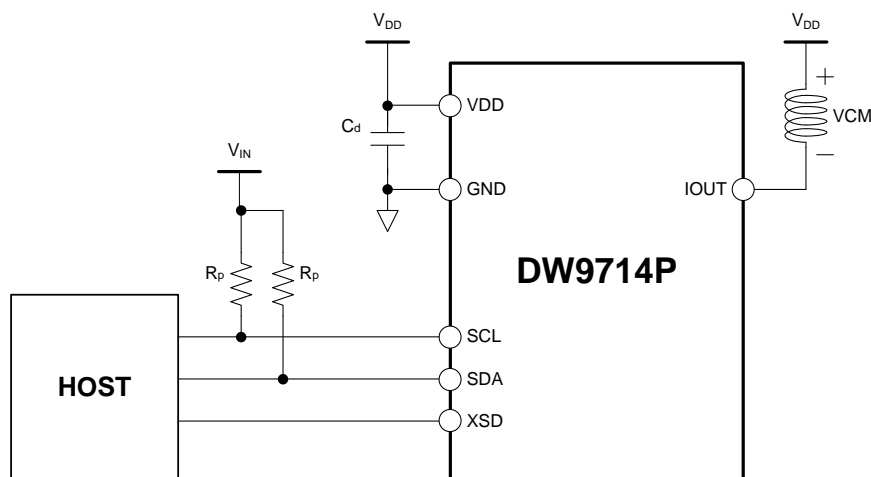
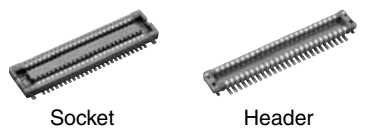

Figure 1. Typical application circuit

NARROW-PITCH, THIN AND SLIM CONNECTOR FOR BOARD-TO-FPC CONNECTION

NARROW PITCH (0.4 mm) CONNECTORS F4S SERIES



Compliance with RoHS Directive

FEATURES

1. Space-saving (3.6 mm widthwise)
 The required space is smaller than our F4 series (40-contact type):
 Socket — 27% smaller,
 Header — 38% smaller
 The small size contributes to the miniaturization of target equipment.

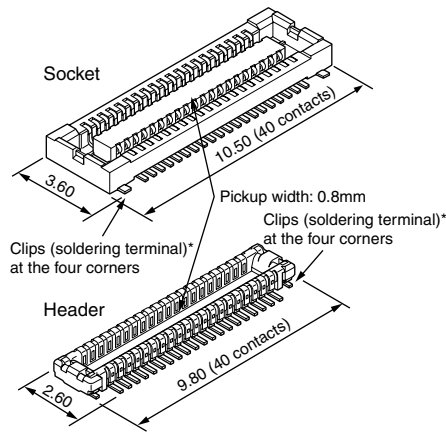

* Clips for preventing the solder joints from being removed

2. Highly reliable
TOUGH CONTACT has strong resistance to adverse environments.
 (See Page 6 for details of the structure)
 Note: If extra resistance to shock caused by dropping is required, we recommend using our previous F4 Series.

3. The simple lock structure gives tactile feedback that ensures a superior mating/unmating operation feel.

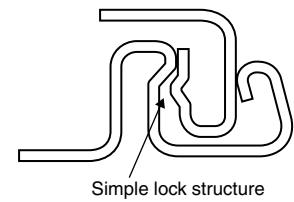

4. Gull-wing type terminals
 The gull-wing type terminals facilitate automatic mounting inspections.
5. Connectors for inspection available
 Connectors for inspection are available that are ideal for modular unit inspection and inspection in device assembly processes.

APPLICATIONS

Compact portable devices “Cellular phones, DVC, Digital cameras, etc”

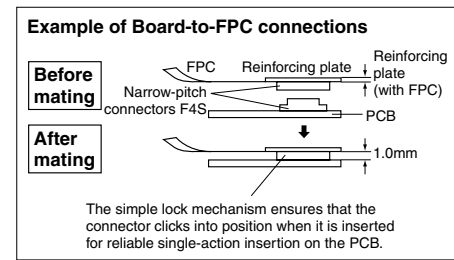

ORDERING INFORMATION

AXT **4**

5: Narrow Pitch Connector F4S (0.4 mm pitch) Socket
 6: Narrow Pitch Connector F4S (0.4 mm pitch) Header

Number of contacts (2 digits)

Mated height
 <Socket>
 1: For mated height 1.0 mm
 2: For mated height 1.2 mm
 <Header>
 1: For mated height 1.0 mm
 2: For mated height 1.2 mm

Functions
 <Socket, Header>
 2: Without positioning bosses

Surface treatment (Contact portion / Terminal portion)
 <Socket>
 4: Base: Ni plating Surface: Au plating (for Ni barrier available)
 <Header>
 4: Base: Ni plating Surface: Au plating

Note: Please note that models with a mated height of 1.0 mm (7th digit of part number is “1”) and 1.2 mm (7th digit of part number is “2”) are not compatible.

AXT5, 6

PRODUCT TYPES

| Mated height | Number of contacts | Part number | | Packing | |
|--------------|--------------------|-------------|-----------|--------------|--------------|
| | | Socket | Header | Inner carton | Outer carton |
| 1.0mm | 10 | AXT510124 | AXT610124 | 3,000 pieces | 6,000 pieces |
| | 12 | AXT512124 | AXT612124 | | |
| | 14 | AXT514124 | AXT614124 | | |
| | 16 | AXT516124 | AXT616124 | | |
| | 18 | AXT518124 | AXT618124 | | |
| | 20 | AXT520124 | AXT620124 | | |
| | 22 | AXT522124 | AXT622124 | | |
| | 24 | AXT524124 | AXT624124 | | |
| | 26 | AXT526124 | AXT626124 | | |
| | 28 | AXT528124 | AXT628124 | | |
| | 30 | AXT530124 | AXT630124 | | |
| | 32 | AXT532124 | AXT632124 | | |
| | 34 | AXT534124 | AXT634124 | | |
| | 36 | AXT536124 | AXT636124 | | |
| | 38 | AXT538124 | AXT638124 | | |
| | 40 | AXT540124 | AXT640124 | | |
| | 42 | AXT542124 | AXT642124 | | |
| | 44 | AXT544124 | AXT644124 | | |
| | 46 | AXT546124 | AXT646124 | | |
| | 48 | AXT548124 | AXT648124 | | |
| 50 | AXT550124 | AXT650124 | | | |
| 54 | AXT554124 | AXT654124 | | | |
| 60 | AXT560124 | AXT660124 | | | |
| 64 | AXT564124 | AXT664124 | | | |
| 70 | AXT570124 | AXT670124 | | | |
| 80 | AXT580124 | AXT680124 | | | |
| 1.2mm | 10 | AXT510224 | AXT610224 | | |
| | 30 | AXT530224 | AXT630224 | | |
| | 40 | AXT540224 | AXT640224 | | |
| | 50 | AXT550224 | AXT650224 | | |
| | 80 | AXT580224 | AXT680224 | | |

- Notes: 1. Order unit: For mass production: in 1-inner-box (1-reel) units
 Samples for mounting check: in 50-connector units. Please contact our sales office.
 Samples: Small lot orders are possible. Please contact our sales office.
2. The above part numbers are for connectors without positioning bosses, which are standard. When ordering connectors with positioning bosses, please contact our sales office.
3. Please contact us for connectors having a number of contacts other than those listed above.

SPECIFICATIONS

1. Characteristics

| | Item | Specifications | Conditions |
|---|--|--|---|
| Electrical characteristics | Rated current | 0.3A/contact (Max. 5 A at total contacts) | |
| | Rated voltage | 60V AC/DC | |
| | Breakdown voltage | 150V AC for 1 min. | No short-circuiting or damage at a detection current of 1 mA when the specified voltage is applied for one minute. |
| | Insulation resistance | Min. 1,000M Ω (initial) | Using 250V DC megger (applied for 1 min.) |
| | Contact resistance | Max. 90m Ω | Based on the contact resistance measurement method specified by JIS C 5402. |
| Mechanical characteristics | Composite insertion force | Max. 0.981N/contacts \times contacts (initial) | |
| | Composite removal force | Min. 0.165N/contacts \times contacts | |
| Environmental characteristics | Contact holding force (Socket contact) | Min. 0.49N/contacts | Measuring the maximum force. As the contact is axially pull out. |
| | Ambient temperature | -55°C to +85°C | No freezing at low temperatures. No dew condensation. |
| | Soldering heat resistance | Peak temperature: 260°C or less (on the surface of the PC board around the connector terminals) 300°C within 5 sec. 350°C within 3 sec. | Infrared reflow soldering Soldering iron |
| | Storage temperature | -55°C to +85°C (product only) -40°C to +50°C (emboss packing) | No freezing at low temperatures. No dew condensation. |
| | Thermal shock resistance (header and socket mated) | 5 cycles, insulation resistance min. 100M Ω , contact resistance max. 90m Ω | Sequence 1. -55 $\frac{3}{5}$ °C, 30 minutes 2. ~, Max. 5 minutes 3. 85 $\frac{3}{5}$ °C, 30 minutes 4. ~, Max. 5 minutes |
| | Humidity resistance (header and socket mated) | 120 hours, insulation resistance min. 100M Ω , contact resistance max. 90m Ω | Bath temperature 40 \pm 2°C, humidity 90 to 95% R.H. |
| | Saltwater spray resistance (header and socket mated) | 24 hours, insulation resistance min. 100M Ω , contact resistance max. 90m Ω | Bath temperature 35 \pm 2°C, saltwater concentration 5 \pm 1% |
| H ₂ S resistance (header and socket mated) | 48 hours, contact resistance max. 90m Ω | Bath temperature 40 \pm 2°C, gas concentration 3 \pm 1 ppm, humidity 75 to 80% R.H. | |
| Lifetime characteristics | Insertion and removal life | 50 times | Repeated insertion and removal speed of max. 200 times/hours |
| Unit weight | | 20-contact type: Socket: 0.03 g Header: 0.01 g | |

2. Material and surface treatment

| Part name | Material | Surface treatment |
|------------------|---------------------|--|
| Molded portion | LCP resin (UL94V-0) | — |
| Contact and Post | Copper alloy | Contact portion: Base: Ni plating Surface: Au plating Terminal portion: Base: Ni plating Surface: Au plating (except the terminal tips) The socket terminals close to the portion to be soldered have nickel barriers (exposed nickel portions). Metal clips: Sockets: Base: Ni plating Surface: Pd+Au flash plating (except the terminal tips) Headers: Base: Ni plating Surface: Au plating (except the terminal tips) |

AXT5, 6

DIMENSIONS (Unit: mm) The CAD data of the products with a **CAD Data** mark can be downloaded from: <http://panasonic-electric-works.net/ac>

Socket (Mated height: 1.0 mm and 1.2 mm)

CAD Data

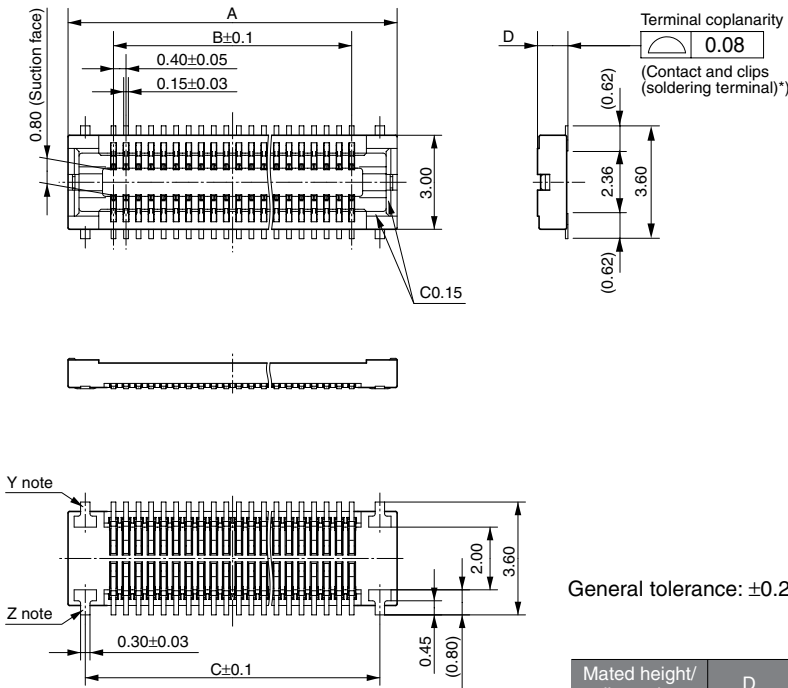

General tolerance: ±0.2

| Mated height/ dimension | D |
|----------------------------|------|
| 1.0mm | 0.97 |
| 1.2mm | 1.17 |

Note: Since the clip (soldering terminal)* has a single-piece construction, sections Y and Z are electrically connected.

Dimension table (mm)

| Number of contacts/ dimension | A | B | C |
|----------------------------------|------|------|------|
| 10 | 4.5 | 1.6 | 3.4 |
| 12 | 4.9 | 2.0 | 3.8 |
| 14 | 5.3 | 2.4 | 4.2 |
| 16 | 5.7 | 2.8 | 4.6 |
| 18 | 6.1 | 3.2 | 5.0 |
| 20 | 6.5 | 3.6 | 5.4 |
| 22 | 6.9 | 4.0 | 5.8 |
| 24 | 7.3 | 4.4 | 6.2 |
| 26 | 7.7 | 4.8 | 6.6 |
| 28 | 8.1 | 5.2 | 7.0 |
| 30 | 8.5 | 5.6 | 7.4 |
| 32 | 8.9 | 6.0 | 7.8 |
| 34 | 9.3 | 6.4 | 8.2 |
| 36 | 9.7 | 6.8 | 8.6 |
| 38 | 10.1 | 7.2 | 9.0 |
| 40 | 10.5 | 7.6 | 9.4 |
| 42 | 10.9 | 8.0 | 9.8 |
| 44 | 11.3 | 8.4 | 10.2 |
| 46 | 11.7 | 8.8 | 10.6 |
| 48 | 12.1 | 9.2 | 11.0 |
| 50 | 12.5 | 9.6 | 11.4 |
| 54 | 13.3 | 10.4 | 12.2 |
| 60 | 14.5 | 11.6 | 13.4 |
| 64 | 15.3 | 12.4 | 14.2 |
| 70 | 16.5 | 13.6 | 15.4 |
| 80 | 18.5 | 15.6 | 17.4 |

Header (Mated height: 1.0 mm and 1.2 mm)

CAD Data

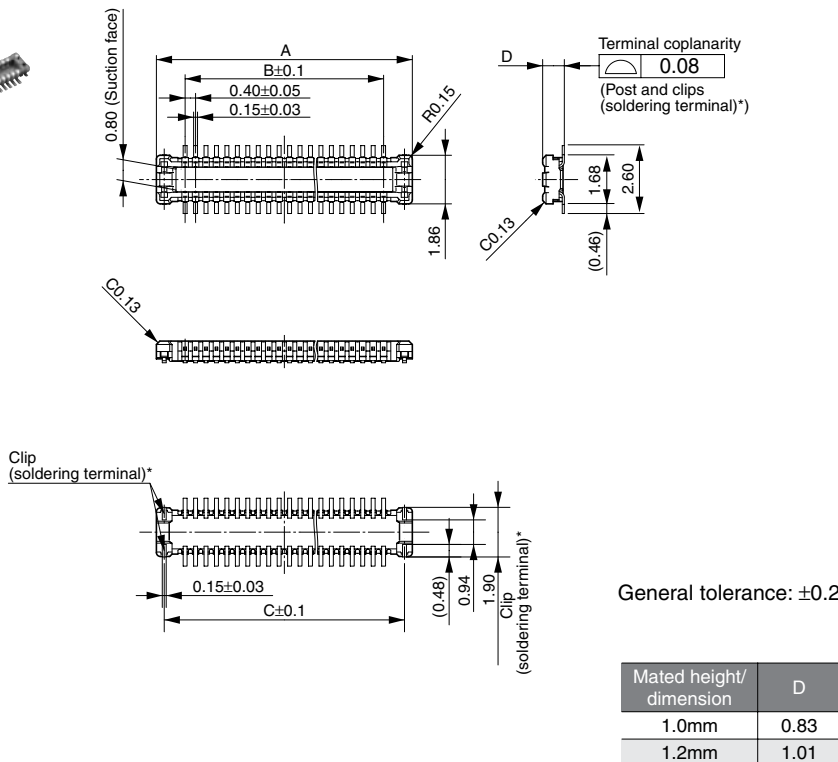

General tolerance: ±0.2

| Mated height/ dimension | D |
|----------------------------|------|
| 1.0mm | 0.83 |
| 1.2mm | 1.01 |

Dimension table (mm)

| Number of contacts/ dimension | A | B | C |
|----------------------------------|------|------|------|
| 10 | 3.8 | 1.6 | 3.2 |
| 12 | 4.2 | 2.0 | 3.6 |
| 14 | 4.6 | 2.4 | 4.0 |
| 16 | 5.0 | 2.8 | 4.4 |
| 18 | 5.4 | 3.2 | 4.8 |
| 20 | 5.8 | 3.6 | 5.2 |
| 22 | 6.2 | 4.0 | 5.6 |
| 24 | 6.6 | 4.4 | 6.0 |
| 26 | 7.0 | 4.8 | 6.4 |
| 28 | 7.4 | 5.2 | 6.8 |
| 30 | 7.8 | 5.6 | 7.2 |
| 32 | 8.2 | 6.0 | 7.6 |
| 34 | 8.6 | 6.4 | 8.0 |
| 36 | 9.0 | 6.8 | 8.4 |
| 38 | 9.4 | 7.2 | 8.8 |
| 40 | 9.8 | 7.6 | 9.2 |
| 42 | 10.2 | 8.0 | 9.6 |
| 44 | 10.6 | 8.4 | 10.0 |
| 46 | 11.0 | 8.8 | 10.4 |
| 48 | 11.4 | 9.2 | 10.8 |
| 50 | 11.8 | 9.6 | 11.2 |
| 54 | 12.6 | 10.4 | 12.0 |
| 60 | 13.8 | 11.6 | 13.2 |
| 64 | 14.6 | 12.4 | 14.0 |
| 70 | 15.8 | 13.6 | 15.2 |
| 80 | 17.8 | 15.6 | 17.2 |

• Socket and Header are mated

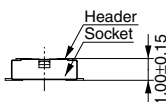

Mated height: 1.0 mm

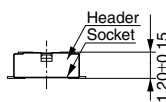

Mated height: 1.2 mm

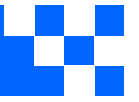

Cameras Applications



Automotive Driver Pilot



Live Streaming



Video Conference



Eye Tracker Biometric Detection

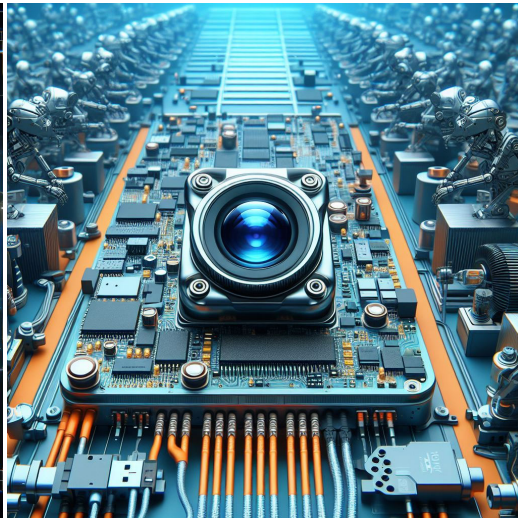

Machine Vision



Agricultural Monitor

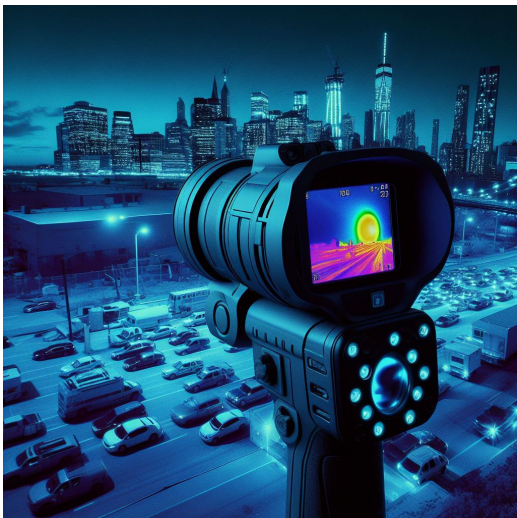

Night Vision Security



Drone and Sports Eagle Eyes



Interactive Pet Camera



your **BEST** camera module partner

Cameras Applications





Camera Module Pinout Definition Reference Chart

| OmniVision | Sony | Samsung | On-Semi | Aptina | Himax | GalaxyCore | PixArt | SmartSens | Sensors |
|-------------------------------|---------|-----------|---------|--------|-------|------------|--------|-----------|---------|
| Pin Signal | | | | | | | | | |
| Description | | | | | | | | | |
| DGND | GND | | | | | | | | |
| AGND | | | | | | | | | |
| PCLK | DCK | | | | | | | | |
| XCLR | PWDN | XSHUTDOWN | STANDBY | | | | | | |
| MCLK | XVCLK | XCLK | INCK | | | | | | |
| RESET | RST | | | | | | | | |
| NC | NULL | | | | | | | | |
| SDA | SIO_D | SIOD | | | | | | | |
| SCL | SIO_C | SIOC | | | | | | | |
| VSYNC | XVS | FSYNC | | | | | | | |
| HREF | XHS | | | | | | | | |
| DOVDD | | | | | | | | | |
| AFVDD | | | | | | | | | |
| AVDD | | | | | | | | | |
| DVDD | | | | | | | | | |
| STROBE | FSTROBE | | | | | | | | |
| FSIN | | | | | | | | | |
| SID | | | | | | | | | |
| ILPWM | | | | | | | | | |
| FREX | | | | | | | | | |
| GPIO | | | | | | | | | |
| SLASEL | | | | | | | | | |
| AFEN | | | | | | | | | |
| MIPI Interface | | | | | | | | | |
| MDN0 | DN0 | MD0N | DATA_N | DMO1N | | | | | |
| MDP0 | DP0 | MD0P | DATA_P | DMO1P | | | | | |
| MDN1 | DN1 | MD1N | DATA2_N | DMO2N | | | | | |
| MDP1 | DP1 | MD1P | DATA2_P | DMO2P | | | | | |
| MDN2 | DN2 | MD2N | DATA3_N | DMO3N | | | | | |
| MDP2 | DP2 | MD2P | DATA3_P | DMO3P | | | | | |
| MDN3 | DN3 | MD3N | DATA4_N | DMO4N | | | | | |
| MDP3 | DP3 | MD3P | DATA4_P | DMO4P | | | | | |
| MCN | CLKN | CLK_N | DCKN | | | | | | |
| MCP | CLKP | MCP | CLK_P | DCKN | | | | | |
| DVP Parallel Interface | | | | | | | | | |
| D0 | DO0 | Y0 | | | | | | | |
| D1 | DO1 | Y1 | | | | | | | |
| D2 | DO2 | Y2 | | | | | | | |
| D3 | DO3 | Y3 | | | | | | | |
| D4 | DO4 | Y4 | | | | | | | |
| D5 | DO5 | Y5 | | | | | | | |
| D6 | DO6 | Y6 | | | | | | | |
| D7 | DO7 | Y7 | | | | | | | |
| D8 | DO8 | Y8 | | | | | | | |
| D9 | DO9 | Y9 | | | | | | | |
| D10 | DO10 | Y10 | | | | | | | |
| D11 | DO11 | Y11 | | | | | | | |



Camera Reliability Test

| Reliability Inspection Item | | Testing Method | Acceptance Criteria | |
|-----------------------------|-----------------------------|---|-------------------------|-------------------------|
| Category | Item | | | |
| Environmental | Storage Temperature | High 60°C 96 Hours | Temperature Chamber | No Abnormal Situation |
| | | Low -20°C 96 Hours | Temperature Chamber | No Abnormal Situation |
| | Operation Temperature | High 60°C 24 Hours | Temperature Chamber | No Abnormal Situation |
| | | Low -20°C 24 Hours | Temperature Chamber | No Abnormal Situation |
| | Humidity | 60°C 80% 24 Hours | Temperature Chamber | No Abnormal Situation |
| | Thermal Shock | High 60°C 0.5 Hours Low -20°C 0.5 Hours Cycling in 24 Hours | Temperature Chamber | No Abnormal Situation |
| Physical | Drop Test (Free Falling) | Without Package 60cm | 10 Times on Wood Floor | Electrically Functional |
| | | With Package 60cm | 10 Times on Wood Floor | Electrically Functional |
| | Vibration Test | 50Hz X-Axis 2mm 30min | Vibration Table | Electrically Functional |
| | | 50Hz Y-Axis 2mm 30min | Vibration Table | Electrically Functional |
| | | 50Hz Z-Axis 2mm 30min | Vibration Table | Electrically Functional |
| | Cable Tensile Strength Test | Loading Weight 4 kg 60 Seconds Cycling in 24 Hours | Tensile Testing Machine | Electrically Functional |
| Electrical | ESD Test | Contact Discharge 2 KV | ESD Testing Machine | Electrically Functional |
| | | Air Discharge 4 KV | ESD Testing Machine | Electrically Functional |
| | Aging Test | On/Off 30 Seconds Cycling in 24 Hours | Power Switch | Electrically Functional |
| | USB Connector | On/Off 250 Times | Plug and Unplug | Electrically Functional |





| Inspection Item | | Inspection Method | Standard of Inspection | | |
|------------------|----------|-------------------|-----------------------------|--|---------------------------------|
| Category | Item | | | | |
| Appearance | FPC/ PCB | Color | The Naked Eye | Major Difference is Not Allowed. | |
| | | Be Torn/Chopped | The Naked Eye | Copper Crack Exposure is Not Allowed. | |
| | | Marking | The Naked Eye | Clear, Recognizable (Within 30cm Distance) | |
| | Holder | Scratches | The Naked Eye | The Inside Crack Exposure is Not Allowed | |
| | | Gap | The Naked Eye | Meet the Height Standard | |
| | | Screw | The Naked Eye | Make Sure Screws Are Presented (If Any) | |
| | | Damage | The Naked Eye | The Inside Crack Exposure is Not Allowed | |
| | Lens | Scratch | The Naked Eye | No Effect On Resolution Standard | |
| | | Contamination | The Naked Eye | No Effect On Resolution Standard | |
| | | Oil Film | The Naked Eye | No Effect On Resolution Standard | |
| | | Cover Tape | The Naked Eye | No Issue On Appearance. | |
| | Function | Image | No Communication | Test Board | Not Allowed |
| | | | Bright Pixel | Black Board | Not Allowed In the Image Center |
| Dark Pixel | | | White board | Not Allowed In the Image Center | |
| Blurry | | | The Naked Eye | Not Allowed | |
| No Image | | | The Naked Eye | Not Allowed | |
| Vertical Line | | | The Naked Eye | Not Allowed | |
| Horizontal Line | | | The Naked Eye | Not Allowed | |
| Light Leakage | | | The Naked Eye | Not Allowed | |
| Blinking Image | | | The Naked Eye | Not Allowed | |
| Bruise | | | Inspection Jig | Not Allowed | |
| Resolution | | | Chart | Follows Outgoing Inspection Chart Standard | |
| Color | | | The Naked Eye | No Issue | |
| Noise | | | The Naked Eye | Not Allowed | |
| Corner Dark | | | The Naked Eye | Less Than 100px By 100px | |
| Color Resolution | | | The Naked Eye | No Issue | |
| Dimension | Height | The Naked Eye | Follows Approval Data Sheet | | |
| | Width | The Naked Eye | Follows Approval Data Sheet | | |
| | Length | The Naked Eye | Follows Approval Data Sheet | | |
| | Overall | The Naked Eye | Follows Approval Data Sheet | | |

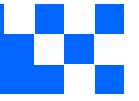

KLT Package Solutions

KLT Camera Module



Complete with Lens Protection Film



Tray with Grid and Space



Place Cameras on the Tray



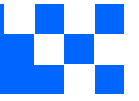

Camera Modules Package Solution

Full Tray of Cameras



Cover Tray with Lid



Put Tray into Anti-Static Bag



Vacuum the Anti-Static Bag

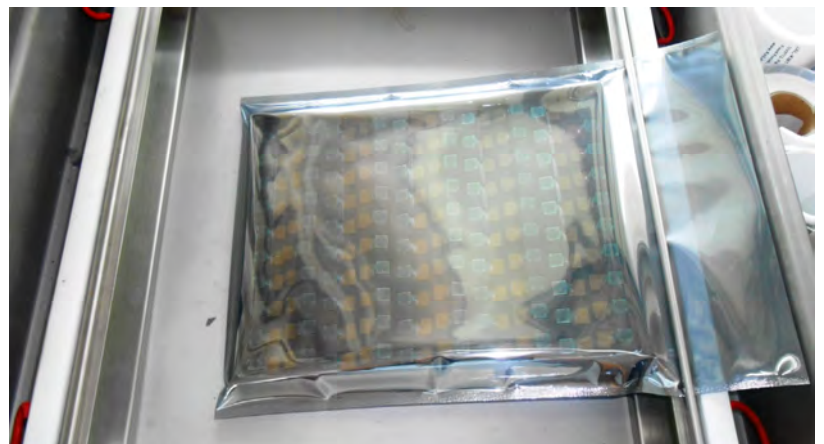



Camera Modules Package Solution

Sealed Vacuum Bag with Labels

1. Model and Description 2. Quantity 3. Shipping Date 4. Caution





Large Order Package Solution

Place Foam Sheets Between Trays



Foam Sheets are Slightly Larger than Trays



Place Foam Sheets and Trays into Box



Foam Sheets are Tightly Fitting Box





Small Order Package Solution

Place Foam Sheets and Trays into Small Box



Foam Sheets are Nicely Fitting the Small Box



Package in Small Box for Shipment



Place Small Boxes into Larger Box





Carbon Box Package Solution

Seal the Carbon Box

Final Package Labelled Box



Carbon Box Ready for Shipment

1. Delivery Address and Phone No. 2. Box No. and Ship Date 3. Fragile Caution





Sample Order Package Solution

Place Sample into Small Anti-Static Bag



Place Connectors into Small Ant-Static Bag



Sample Labels on the Small Bag

1. Camera Module or Connector Model
2. Shipping Date and Quantity
3. Caution





Connectors Large Order Package Solution

Connectors in a Wheel



Label Connectors in the Wheel



The Wheel is Perfectly Fitting the Box



Connectors Box Ready for Shipment





your BEST camera module partner

Company Kai Lap Technologies (KLT)

Kai Lap Technologies Group Limited. (KLT) was established in 2009, a next-generation technology driven manufacturer specialized in research, design, and produce of audio and video products. KLT is occupying 20,000 square feet automated plants with 100 employees of annual throughput 30,000,000 units cameras.

KLT provides OEM, ODM design, contract manufacturing, and builds the camera products. You may provide the requirements to us, even with a hand draft, our sales and engineering work together to meet your needs. We consider ourselves your last-term partner in developing practical and innovative solutions.

Our team covers everything from initial concept development to mass produced product. KLT specializes in customized camera design, raw material, electronic engineering, firmware/software development, product testing, and packing design. Our experienced strategic supply systems offer a robust and dependable manufacturing capacity for orders of various sizes.

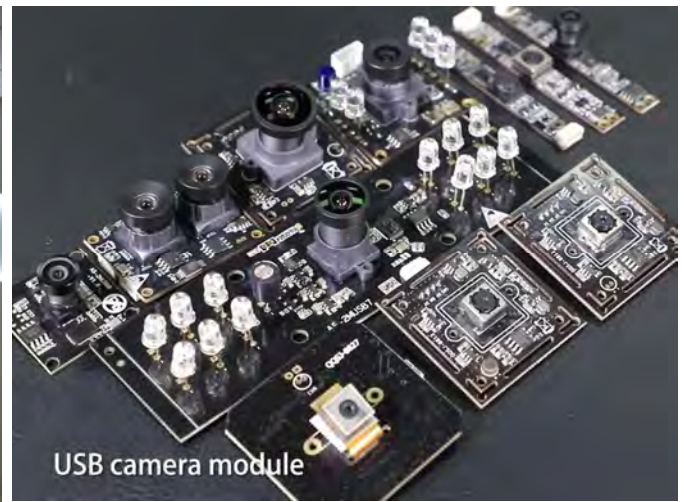

Limited Warranty

KLT provides the following limited warranty if you purchased the Product(s) directly from KLT company or from KLT's website, www.KaiLapTech.com. Product(s) purchased from other sellers or sources are not covered by this Limited Warranty. KLT guarantees that the Product(s) will be free from defects in materials and workmanship under normal use for a period of one (1) year from the date you receive the product ("Warranty Period").

For all Product(s) that contain or develop material defects in materials or workmanship during the Warranty Period, KLT will, at its sole option, either: (i) repair the Product(s); (ii) replace the Product(s) with a new or refurbished Product(s) (replacement Product(s) being of identical model or functional equivalent); or (iii) provide you a refund of the price you paid for the Product(s).

This Limited Warranty of KLT is solely limited to repair and/or replacement on the terms set forth above. KLT is not reliable or responsible for any subsequent events.





CMOS CAMERA MODULES



your BEST camera module partner

KLT Strength

Powerful Factory



Professional Service



Promised Delivery



www.KaiLapTech.com sales@KaiLapTech.com Tel: (852) 6908 1256 Fax: (852) 3017 6778

All rights reserved @ Kai Lap Technologies Group Ltd. Specifications subject to change without notice.